

---

## LCTG—Notes Part 5: LIG, and LTAG

1

---

### Dutch Infinitival Complements

- Dutch has the following basic word order in subordinate clauses, in which dependencies cross:
  - Ik denk dat Subj-Obj(etc)-Adjunct-V[+fin]-(V[-fin](etc))-Sentential Complement
- (3) Ik denk dat ik<sub>1</sub> Cecilia<sub>2</sub> de nijlpaarden<sub>2</sub> zag<sub>1</sub> voeren<sub>2</sub>  
I think that I Cecilia the hippos saw feed  
*I think that I saw Cecilia feed the hippos*
- (4) Ik denk dat ik<sub>1</sub> Cecilia<sub>2</sub> Henk<sub>3</sub> de nijlpaarden<sub>3</sub> zag<sub>1</sub> helpen<sub>2</sub> voeren<sub>3</sub>  
I think that I Cecilia Henk the hippos saw help feed  
*I think that I saw Cecilia help Henk feed the hippos*

3

---

## Multiple Dependencies

- The Complex NP Constraint
- (1) a. ?a cake<sub>j</sub> which I met a man<sub>i</sub> who t<sub>i</sub> ate t<sub>j</sub>  
b. \*a man<sub>i</sub> who(m) I bought a cake<sub>j</sub> which t<sub>i</sub> had baked t<sub>j</sub>
- Violins and Sonatas The ATN HOLD register is a GPSG SLASH is a stack?
- (2) a. a violin<sub>i</sub> which the Moonlight Sonata<sub>j</sub> is easy to play t<sub>j</sub> on t<sub>i</sub>.  
b. \*a sonata<sub>i</sub> which this Stradivarius violin<sub>j</sub> is easy to play t<sub>i</sub> on t<sub>j</sub>.

2

---

### Linear Indexed Grammars (LIG)

- Treating a single slash feature as a stack gives us a Linear Indexed Grammar (LIG). A LIG is little more powerful than CFG but much less powerful than CSG, let alone a Turing machine, and will do crossed as well as nested dependencies, including the Dutch case.
- LIG is a natural family of languages in the Chomsky hierarchy, in the sense that it is associated with a characteristic automaton, the Embedded PDA (EPDA Joshi et al. 1991).
- LIG is one of an infinite hierarchy of Linear Context Free Rewriting Systems (LFCRS), all of which share “mildly context sensitive” power, in that the languages they generate share properties like Constant Growth and Semilinearity, unlike some context sensitive languages.
- LIG falls just above the CF class in the hierarchy.
- It is therefore “nearly context free”.

4

## A LIG for $a^n b^n$ Crossed

- LIG can capture crossing dependencies.

$$(5) A_{[...]} \rightarrow \alpha B_{[...]} \beta$$

$$(6) \text{“pushing”}: A_{[...]} \rightarrow \alpha B_{[i,...]} \beta$$

$$\text{“popping”}: A_{[i,...]} \rightarrow \alpha B_{[...]} \beta$$

$$(7) S_{[...]} \rightarrow n_i S_{[i,...]}$$

$$S_{[...]} \rightarrow S'_{[...]}$$

$$S'_{[i,...]} \rightarrow S'_{[...]} v_i$$

$$S'_{[]} \rightarrow \epsilon$$

5

## Example: A LIG Derivation for $n^3 v^3$ Crossed

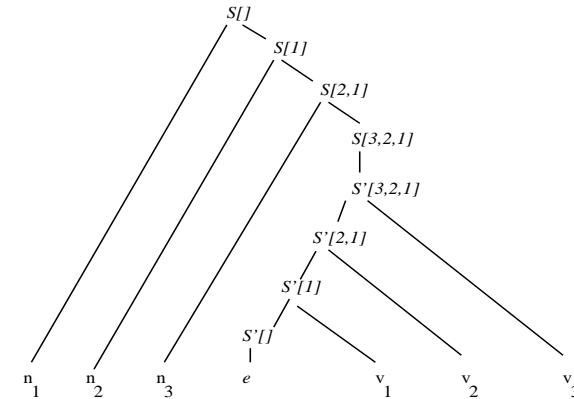

Figure 1: (Weakly adequate) LIG derivation for  $n^3 v^3$

6

## An Answer to Chomsky's Implicit Question?

- Later in the course we will see that LIG offers a convincing candidate for a **upper bound on the complexity of Natural Grammars**.
- However, the above LIG is only weakly adequate. Coordination shows that we need more flexibility in the structural analysis of both NP and VP clusters.

7

## Lexicalized Tree Adjoining Grammars (LTAG)

- Lexicalized Tree Adjoining Grammars (LTAG) associate an *elementary tree* with every lexical item.
- Elementary trees are direct descendants of the *Kernel Sentences* that we saw in the reading from Chomsky 1957. They differ in being lexicalized, rather than being part of generative syntax. But they are still describable using a language specific GPSG-like context free grammar.
- Elementary trees are either *initial trees* or *auxiliary trees*.
- Elementary trees combine by two operations of *substitution* (which is just what it says) and *adjunction* (which is a little harder to explain).
- Substitution and Adjunction are reminiscent of the Double-based or “Generalized” transformations of Chomsky 1957.

8

## LTAG Initial ( $\alpha$ ) Trees

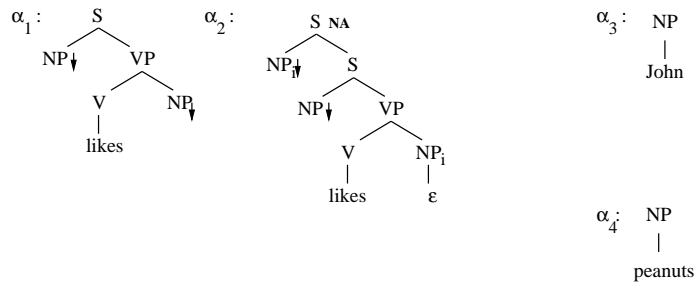

Figure 2: Initial Trees

- Down arrow  $\downarrow$  on a category like NP means “an NP must be substituted here.”

9

## LTAG Auxiliary ( $\beta$ ) Trees

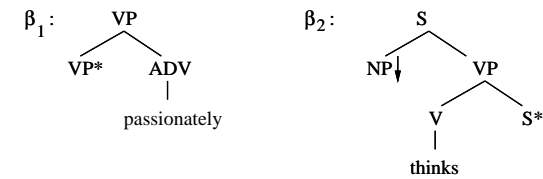

Figure 3: Auxiliary Trees

- An asterisk \* on a category like S means “this S must adjoin to S.” NA on a category like S means “adjoining at this S is not allowed.” The NA annotation on the initial tree in the last slide will prevent *\*Bill thinks peanuts, John likes.*

10

## A Derivation involving Substitution and Adjunction

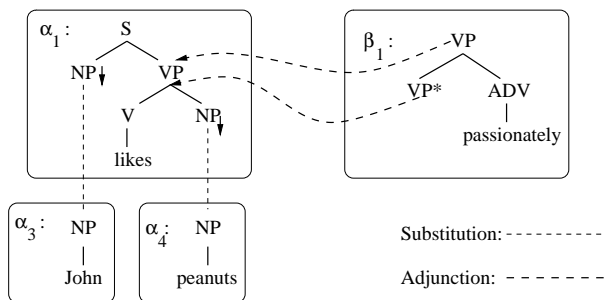
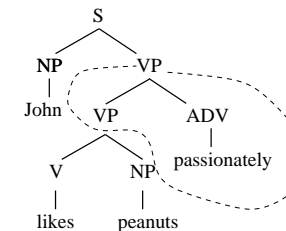

Figure 4: A derivation

- Recall that a asterisk \* on a category like S means “this S must adjoin to S.”

11

## A Derivation (Contd.)



12

## Unbounded Dependency: Topicalization

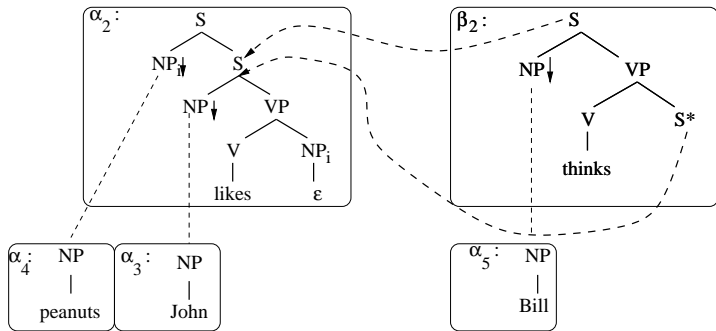

Figure 5: Derivation of long-distance topicalization

- Clearly we could adjoin unboundedly many auxiliary trees like  $\beta_2$ .

13

## Unbounded dependency (Contd.)

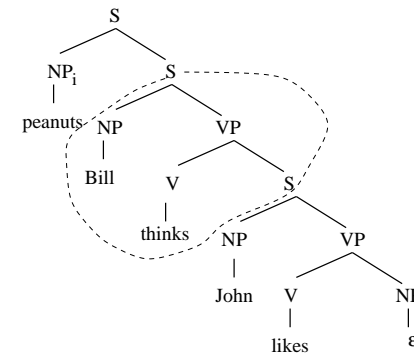

Figure 6: Result of the Derivation

14

## The “Raising” Construction in TAG

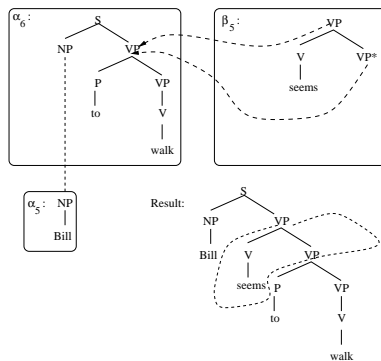

Figure 7: Raising as Adjunction

- Semantically this is function composition.

15

## The “Control” Construction in TAG

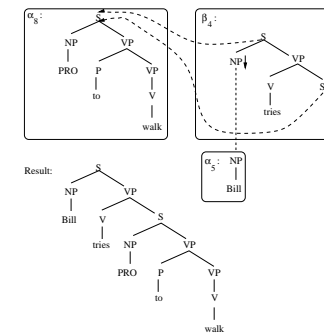

Figure 8: Control as Adjunction

- Since adjunction is at a root node, one might think this could be handled with substitution alone. However by analogy with Figure 5, we need adjunction to generalise to *These men, Bill tries to like*.

16



## Crossing Dependencies (Contd.)

- Piet Marie helpen zwemmen

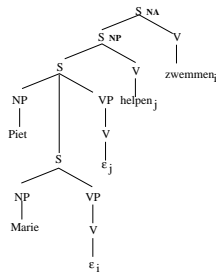

Figure 12: The Result of One Adjunction

21

## Crossing Dependencies (Contd.)

- Jan Piet Marie zag helpen zwemmen

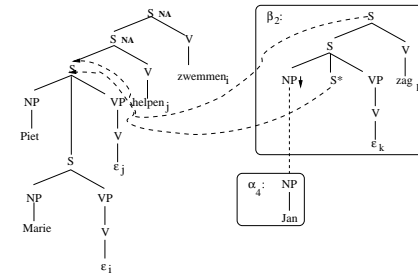

Figure 13: The Crucial Adjunction

22

## Crossing Dependencies (Contd.)

- (dat) Jan Piet Marie zag helpen zwemmen

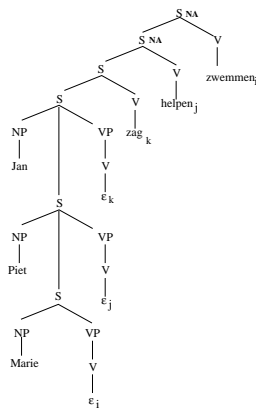

Figure 14: The Result of Two Adjunctions

23

## Discussion

- This does not yet explain coordinations like the following.
  - (dat) Jan Piet Marie en ik Cecilia de nijlpaarden zag helpen zwemmen.  
(that) Jan Piet Marie and I Cecilia the hippos saw help swim.
  - (dat) Jan Piet en ik Cecilia de nijlpaarden zag helpen zwemmen.  
(that) Jan Piet and I Cecilia the hippos saw help swim.
  - (dat) Jan Piet Marie zag helpen zwemmen en hoorde leren zingen.  
(that) Jan Piet Marie saw help swim and heard teach sing.
- These are all instances of (a generalization of) Ross's Generalization concerning gapping and the order of constituency.

24